



ABOUT YOUR HOUSE

ASSESSING THE COMFORT AND SAFETY OF YOUR HOME'S MECHANICAL SYSTEMS

CE 28 k

The heating, ventilating and air conditioning (HVAC) systems are a vital part of every home. These mechanical systems help control the indoor conditions you need for comfort, health and safety. How these mechanical systems interact with other appliances is critical in keeping your home's indoor environment healthy and safe.

Conventional oil furnace or boiler

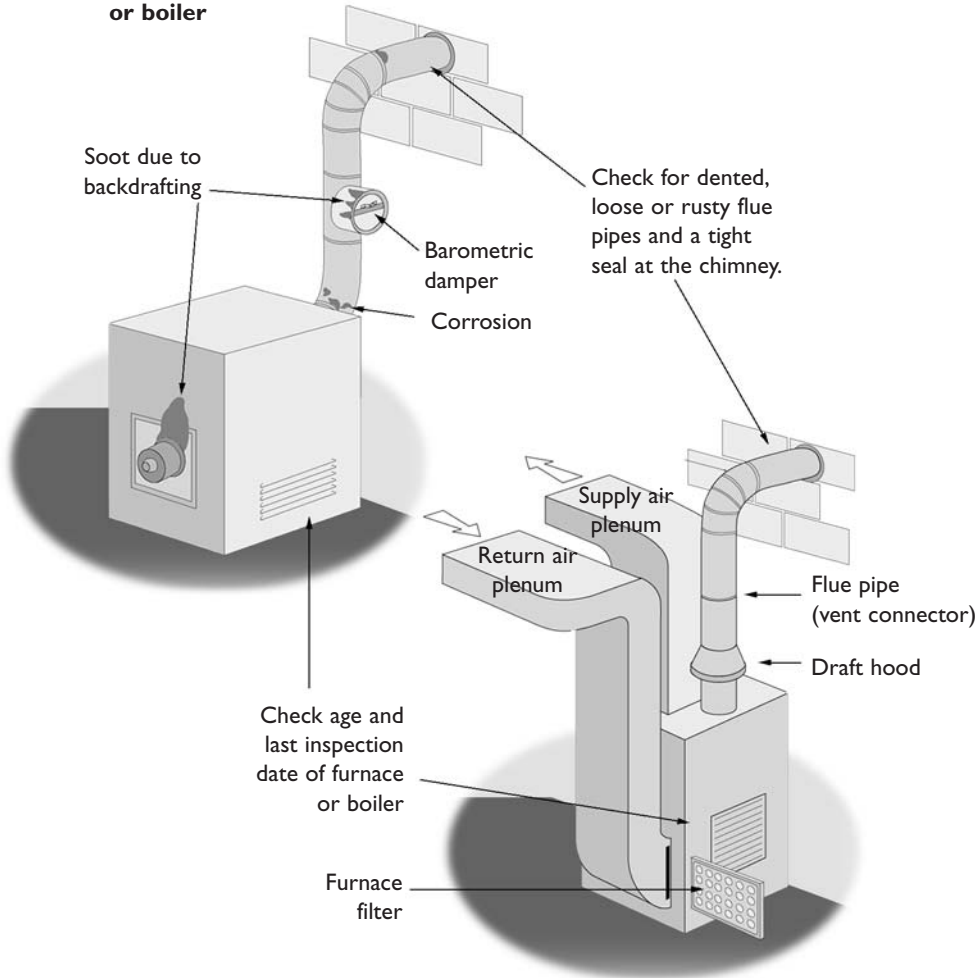

Conventional natural gas or propane forced air furnace

Common Situations

Equipment that is not sized or operating properly is less effective, may use more energy, have higher operating costs and compromise the health and safety of all occupants.

There are many reasons that may prompt you to assess the comfort and safety of your HVAC equipment:

- **Equipment age and noise**—old equipment may not provide adequate heat and air exchange. A deteriorating or improperly installed system can be noisy.
- **Smells**—wood smoke or combustion gas smells may indicate chimney problems or dangerous spillage from fuel burning equipment. Inadequate air exchange may cause stale air or lingering smells.
- **Comfort**—there may be cold spots, excessive dust, humidity problems or stale air that makes the house noticeably uncomfortable.
- **Other renovation work**—this can be an opportune time to modernize the heating system in the house and to install a proper ventilation system where one does not exist. It is important that mechanical systems do not change the balance between the air pressure inside the house and the air pressure outside. Lower air pressure inside the house can lead to problems of combustion spillage from furnaces, hot water heaters or fireplaces. Many modern kitchens incorporate very powerful exhaust fans that can cause major pressure differences.

Healthy Housing™

Renovating is an ideal time to make your house healthier for you, the community and the environment. When assessing the comfort and safety of your mechanical systems, be sure to consider:

- **Occupant health**—adequacy of exhaust systems for combustion appliances, a ventilation system for occupants.
- **Energy efficiency**—efficiency of motors in the heating and ventilation equipment, efficiency of heating, cooling and hot water heating equipment.

House as a System

A house is much more than just four walls and a roof—it's an interactive system made up of many components including the basic structure, heating, ventilating and air conditioning (HVAC) equipment, the external environment and the occupants. Each component influences the performance of the entire system. A renovation provides an opportunity to improve how your house performs.

- **Resource efficiency**—measures to reduce space heating needs (upgrading insulation, draftproofing, HVAC appliances that use the least amount of energy, solar and wind energy) to reduce the home's environmental impact.
- **Environmental responsibility**—HVAC appliances and occupant practices to reduce energy environmental impacts.
- **Affordability**—energy efficient appliances to reduce ongoing operating costs.

The comfort and safety of HVAC systems very much depends on how the equipment is integrated into the house. Exhaust fans must not compromise the venting of combustion appliances. Additional fans may require special provisions for make-up air. Structural changes made as part of renovations may improve draft proofing and insulation, resulting in increased occupant comfort and house durability. However, these changes may alter the venting of combustion appliances and the supply of fresh air for occupants.

Avoid Surprises

Knowing the properties and operating characteristics of your heating and ventilation system will help you to decide the changes you may want to

consider. Here are some of the likely situations that people encounter. However, every situation is unique and you may need to hire a qualified

professional to do a thorough investigation, find the problems and suggest the best solutions.

Ask yourself ...

Consider your options ...

... and if you don't

Equipment age and noise

- How old is the furnace?
- When was the last maintenance service done?

- Repair or replace old equipment. Every piece of equipment has a natural life span even if it's maintained correctly.
- Maintain equipment regularly so that it operates safely and efficiently.

- Old furnace motors are not as efficient as newer models. Hot water-based heating systems may have inefficient boilers and pumps.
- Inadequate maintenance shortens equipment life span and can lead to premature failure, incomplete fuel combustion and backdrafting of combustion gases. Clogged filters are a fire hazard. Cracked heat exchangers allow combustion gases into the home's air.

- Is the heating system making too much noise?

- Have your HVAC system assessed by a professional HVAC contractor. Noise in a forced warm air heating system may be the result of fans and blowers that are not maintained or properly attached to the house structure. Noise can also be created because of undersized ducts.
- In water based (hydronic) heating systems, noise may be generated as pipes expand and contract when the system heats up and cools down. Some noise may be the result of improperly attached pipes that do not allow for thermal expansion and contraction. The water in the system could also be too hot.

- Noisy heating system components, particularly fans and pumps, can suggest that they are near the end of their useful life and could fail at any time.

Ask yourself ...

Consider your options ...

... and if you don't

Smells

- | | | |
|---|--|---|
| <ul style="list-style-type: none">• Is there a wood smoke smell from the fireplace in the house? Are there combustion smells? | <ul style="list-style-type: none">• Investigate the source of the smells and take action to correct the problem. Regularly noticing smells from combustion gases and wood smoke from the fireplace or other combustion appliances in the house suggests that the flue is not functioning properly. It may also be the result of pressure imbalances in the house that can be solved by flue maintenance, properly balancing the heating system and adding make-up air. | <ul style="list-style-type: none">• Combustion by-products are toxic and in the worst cases can cause death. |
| <ul style="list-style-type: none">• Does smoke come into the house from the chimney? Are there fuel smells in the furnace area? | <ul style="list-style-type: none">• Get the chimney inspected and cleaned by a qualified tradesperson. | <ul style="list-style-type: none">• Blocked and dirty flues are a fire hazard. If flues are blocked entirely, then combustion gases will spill into the house, which can have serious health impacts and can cause death. |
| <ul style="list-style-type: none">• Are there any fuel-burning appliances in the house? Are there any smoke or gas detectors? | <ul style="list-style-type: none">• Install a smoke detector and a carbon monoxide (CO) detector to alert you to any combustion gas spillage that may be occurring. | <ul style="list-style-type: none">• Combustion gas spillage is a major safety risk that can have serious health impacts at high concentrations. Carbon monoxide is toxic and can cause death. |

Comfort

- | | | |
|--|--|---|
| <ul style="list-style-type: none">• Is there even distribution of heat throughout the house? Are there cold spots? | <ul style="list-style-type: none">• Make sure the warm air registers (or hot water valves in a hydronic system) are open to allow heat in.• Upgrade the insulation in cold areas. Cold spots can be caused by an improperly laid out or inadequate heating system.• Balance the heating system and seal the ducts. This will likely be needed when major renovations are being done and if the heating ducts (or hot water pipes) are exposed. | <ul style="list-style-type: none">• Cold spots in the house, especially on outside walls and ceilings, are areas where condensation will occur. Condensation, dust and other organic material on the wall surface creates ideal conditions for mold growth that can compromise indoor air quality (IAQ) in the house. |
|--|--|---|

Ask yourself ...

Consider your options ...

... and if you don't

Comfort (cont'd)

- | | | |
|--|--|---|
| <ul style="list-style-type: none"> • Are there heating ducts or pipes that run through unheated space such as an unheated crawl space or in the attic area? | <ul style="list-style-type: none"> • Consider using supplementary heaters or booster fans to provide additional heat. This could be an electric heater or electric radiant panels in the floor. | <ul style="list-style-type: none"> • Improper or inadequate adjustment of the heating system can create excessive pressure imbalances in the room. This could affect the operation of combustion appliances in the house. • Adjustments after a renovation may require changes to the finished work. |
| <ul style="list-style-type: none"> • Are there areas of the house that always seem drafty and uncomfortable? | <ul style="list-style-type: none"> • Air-seal and insulate the ducts or water pipes to reduce heat loss in unheated spaces. Consider relocating the ducts. • Air-seal the house including repairing or replacing window and door weatherstripping. Areas that are constantly drafty suggest large amounts of air leakage. | <ul style="list-style-type: none"> • Heat will continue to be lost through uninsulated ducts or pipes. Condensation can form in the ducts, which can cause moisture problems and be a breeding ground for mold. Ducts can also carry dust, mold spores and other contaminants that can be drawn into the house. • Outdoor air will continue to enter, carrying in pollens and dust from the outside. • Warm air carrying moisture can escape through cracks and pores of the building causing moisture problems indoors. |
| <ul style="list-style-type: none"> • Is it difficult to maintain comfort conditions? | <ul style="list-style-type: none"> • Replace old controls. Maintaining constant temperatures requires good controls. Place thermostat in a location that is out of the sun to get an accurate reading of the average house temperature. • Consider zoning the house, so that the sunny south side would be on its own zone, while areas in constant shade or on the north side would have their own control. | <ul style="list-style-type: none"> • Comfort conditions will be hard to maintain. Older thermostats are not as accurate as today's electronic models. Electric heaters with built-in thermostats are especially vulnerable to wide temperature swings as the heating element itself influences the thermostat. |

Ask yourself ...

Consider your options ...

... and if you don't

Comfort (cont'd)

- | | | |
|---|---|---|
| <ul style="list-style-type: none">• Does there seem to be stale air in the house? Do smells linger?• Is the house too humid? | <ul style="list-style-type: none">• Install a heat recovery ventilator that can operate continuously, at low speed. Exhaust-only ventilation systems do not provide a balanced flow (like heat recovery ventilators) and can result in lower air pressures in the house, compared to the outside. This can cause combustion appliances to backdraft.• Choose a quiet, good quality fan for the main bathroom with a timer switch that can be set to operate at least eight hours in every 24, either in one period, or in several periods spread over the day and night. Make sure that the kitchen range hood fan exhausts to the exterior. | <ul style="list-style-type: none">• Improperly placed thermostats that are too close to a heating element, an outside door or in direct sunlight will not be able to provide a proper control function. |
| <ul style="list-style-type: none">• Is the house very dusty? | <ul style="list-style-type: none">• Air-seal and draftproof the house. High dust levels in the house are a sign of excessive air leakage from outside.• Vacuum frequently to remove dust. | <ul style="list-style-type: none">• Inadequate air change rates in the house create poor indoor air quality conditions that can compromise health over time.• Excessive humidity build-up can deteriorate finishes, the structure and contribute to mold growth. |
| | | <ul style="list-style-type: none">• The house will continue to be drafty and dusty.• If the fan does not operate continuously, the filter will not do anything. Continuous operation of an improperly sized fan with an inefficient motor can increase electrical power consumption. |

Ask yourself ...

Consider your options and if you don't

Comfort (cont'd)

- Add a medium efficiency pleated filter or electronic filter to the forced air heating system. The filter will capture a lot of the dust within the house. However, the fan must be adequately sized and set to operate continuously to move air past the filter.

- Is the house too humid or too dry at various times of the year?
 - Repair, replace or install a new mechanical ventilation system. High humidity in the winter is usually an indicator of very low air exchange in a well air-sealed house. Some houses may have high humidity in the summer. This may be a result of local climate conditions (hot, humid, summer weather in central Canada).
 - Install a dehumidifier, especially if the house is not air-conditioned. An air-conditioning system should help dehumidify the air. Too low a humidity level in the winter is an indicator of excessive air change rates. Air sealing the house will reduce the uncontrolled air change.
 - High humidity creates unhealthy conditions. Molds, fungi and mites thrive in warm, damp environments.
 - Excessively dry conditions dry our mucous membranes, lowering our resistance to bacteria.

Ask yourself ...

Consider your options ...

... and if you don't

Other renovation work

- Is there any renovation work planned that will require changes in the HVAC equipment or ducts throughout the house?
- Will a new addition exceed the demand of the current HVAC equipment?
- Assess how extensive the changes will need to be to the HVAC system. If significant changes are planned or your system is close to the end of its life span, it may be cost effective to install new, more efficient equipment. Remember that the house is a system. New windows or air sealing may reduce the demand of HVAC or create the need for controlled make-up or combustion air.
- Upgrade or replace the HVAC equipment to meet new demands.
- New equipment may need to be installed in the near future that could cause added disruption.
- Undersized or inadequate equipment will not provide the comfort and service that you expect.

Rewards

- A properly operating HVAC system not only maintains comfortable indoor conditions, but also ensures a healthier home environment for you and your family.
- Your new mechanical systems will have lower operating costs, increased safety and give you peace of mind.

Skills to Do the Job

Basic mechanical systems maintenance, including filter replacement and motor oiling as identified in manufacturers' manuals, is a job you can do. However, qualified HVAC

contractors must do any adjustments or equipment upgrades that are needed.

Your local energy utilities and heating industry associations can give you information and refer

you to competent tradespeople. Heating systems distributors in your area can also give you references to the local associations and tradespeople.

Use the Mechanical Systems Safety and Comfort Assessment Worksheet to record the present condition, any problems with your mechanical system and preliminary costing.

Mechanical Systems Safety and Comfort Assessment Worksheet		
Type of heating system		
Year installed		
Last time service performed (there should be a service technician's sticker on the unit.)		
Last filter change		
Oil or woodburning stoves or fireplaces?		
Last time the chimney was cleaned?		
Can smoke be smelled in the house?		
Comfort Issues	Present condition/Problems	Cost
• Noise		
• Dust		
• Uneven heat distribution (cold spots in the house)		
• Lingering smells		
• Fuel smells		
• Too humid in winter		
• Too dry in winter		
• Too hot in summer		
Other		

Costing Your Project

Cost of maintenance and system upgrades will depend on the work that needs to be done. Simple housekeeping work that you can do

will cost nothing other than any needed replacement oil or filters.

When reviewing bids from contractors for equipment

replacement or modifications, make sure that the quotations you are comparing are for similar work, including the same or truly equivalent equipment.

The EnerGuide for Houses™ service provides a thorough home energy analysis. It has been developed by Natural Resources Canada (NRCan) and is delivered by local service organizations across Canada for a fee. Retrofits may be eligible for grants until 2007.

To find a local service organization or grant information, visit www.energuideforhouses.gc.ca or call 1-800-387-2000.

To find more About Your House fact sheets plus a wide variety of information products, visit our Web site at www.cmhc.ca. You can also reach us by telephone at 1 800 668-2642 or by fax at 1 800 245-9274.

Priced Publications

<i>Healthy Housing Renovation Planner</i>	Order No. 60957
<i>Homeowner's Inspection Checklist</i>	Order No. 62114
<i>Renovator's Technical Guide</i>	Order No. 61946
<i>The Clean Air Guide: How to Identify and Correct Indoor Air Problems in Your Home</i>	Order No. 61082

Free Publications

<i>A Guide to Mechanical Equipment for Healthy Indoor Environments</i>	Order No. 62015
--	-----------------

About Your House fact sheets:

<i>Measuring Humidity in Your Home</i>	Order No. 62027
<i>Combustion Gases in Your Home</i>	Order No. 62028
<i>Your Furnace Filter</i>	Order No. 62041
<i>Hiring a Contractor</i>	Order No. 62277
<i>Assessing the Comfort and Safety of Your Home's Mechanical Systems</i>	Order No. 62266
<i>Sample Renovation Contract</i>	Order No. 62351

©2000, Canada Mortgage and Housing Corporation
Printed in Canada
Produced by CMHC
Revised 2003, 2005

04-03-05

Although this information product reflects housing experts' current knowledge, it is provided for general information purposes only. Any reliance or action taken based on the information, materials and techniques described are the responsibility of the user. Readers are advised to consult appropriate professional resources to determine what is safe and suitable in their particular case. Canada Mortgage and Housing Corporation assumes no responsibility for any consequence arising from use of the information, materials and techniques described.